

NOTES:

1. INLET AND OUTLET: 3/4" MNPT
2. SUCTION PORT: 1/4" (ID) TUBING BARB SHANK OR 1/4" MNPT
3. MATERIAL OF CONSTRUCTION: GLASS REINFORCED POLYPROPYLENE OR PVDF (KYNAR)
4. MAXIMUM TEMPERATURE RATING:
  - POLYPROPYLENE: 150 F. (65.5 C.)
  - PVDF: 200 F. (93.3 C.)
5. MAXIMUM PRESSURE RATING AT 68 F. (20 C.)
  - POLYPROPYLENE: 150 PSIG (10.3 BAR)
  - PVDF: 200 PSIG (13.8 BAR)

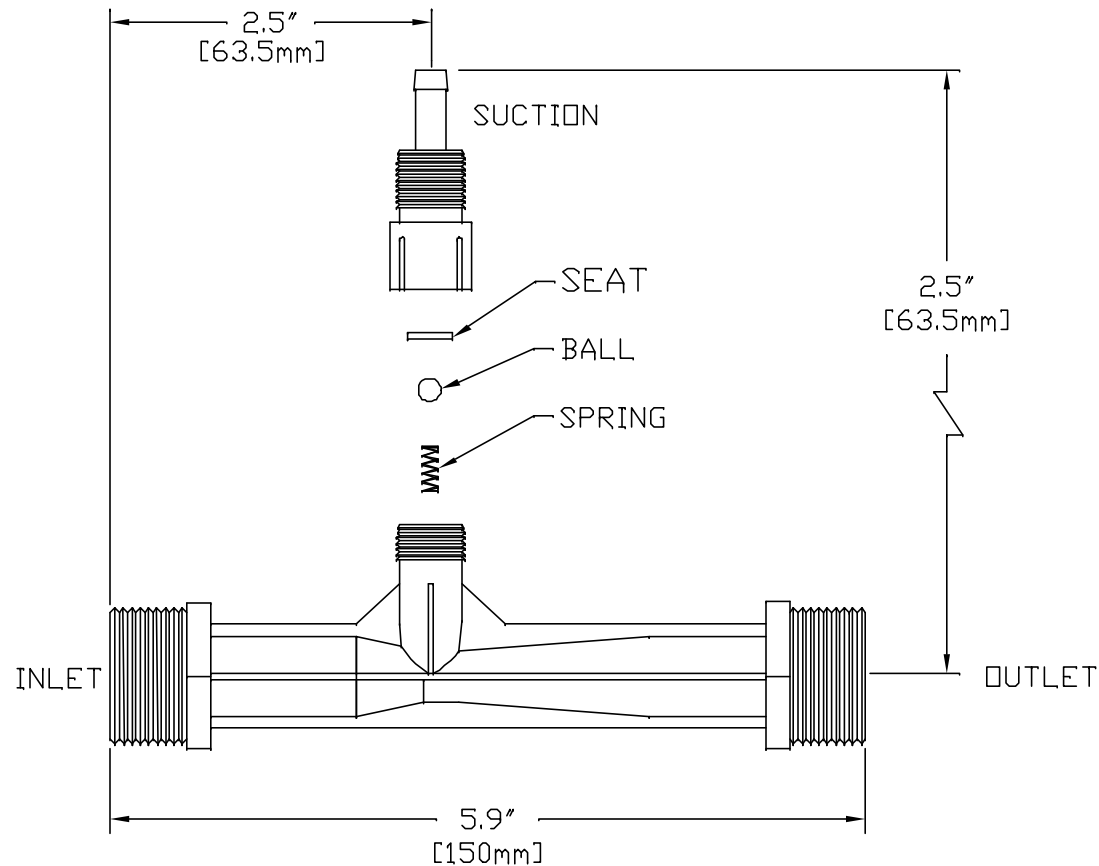

Covered By United States Patent No. 5,863,128  
International Patents Pending



Mazzei Injector Company, LLC  
500 Rooster Drive, Bakersfield, CA 93307  
Tel: 661.363.6500 Fax: 661.363.7500

DATE	12-15-00	TITLE	
DRAWN BY	JRM	MODEL 784 INJECTOR	
REVIEWED BY	RST	NUMBER	JRM-13
SCALE	NONE	SIZE	REV.
MATERIALS:	SEE NOTES	PAGE (1) OF (1)	